

NOTES:
 1. ALL CALLOUTS ENCLOSED IN PARENTHESES () OR UNDERLINED ARE FOR REFERENCE ONLY.

ITEM NO.	DESCRIPTION	PART NO.
1	PUMP DISCHARGE GAUGE	
2	PERMEATE FLOWMETER	
3	CONCENTRATE FLOWMETER	
4	RECYCLE FLOWMETER	
5	SYSTEM CONTROLLER	
6	5 MICRON SEDIMENT FILTER	
7	FILTER PRESSURE GAUGE	
8	SOLENOID VALVE	
9	MEMBRANE VESSEL	
10	SYSTEM PUMP	
11	PRESSURE SWITCH	
12	CHECK VALVE	

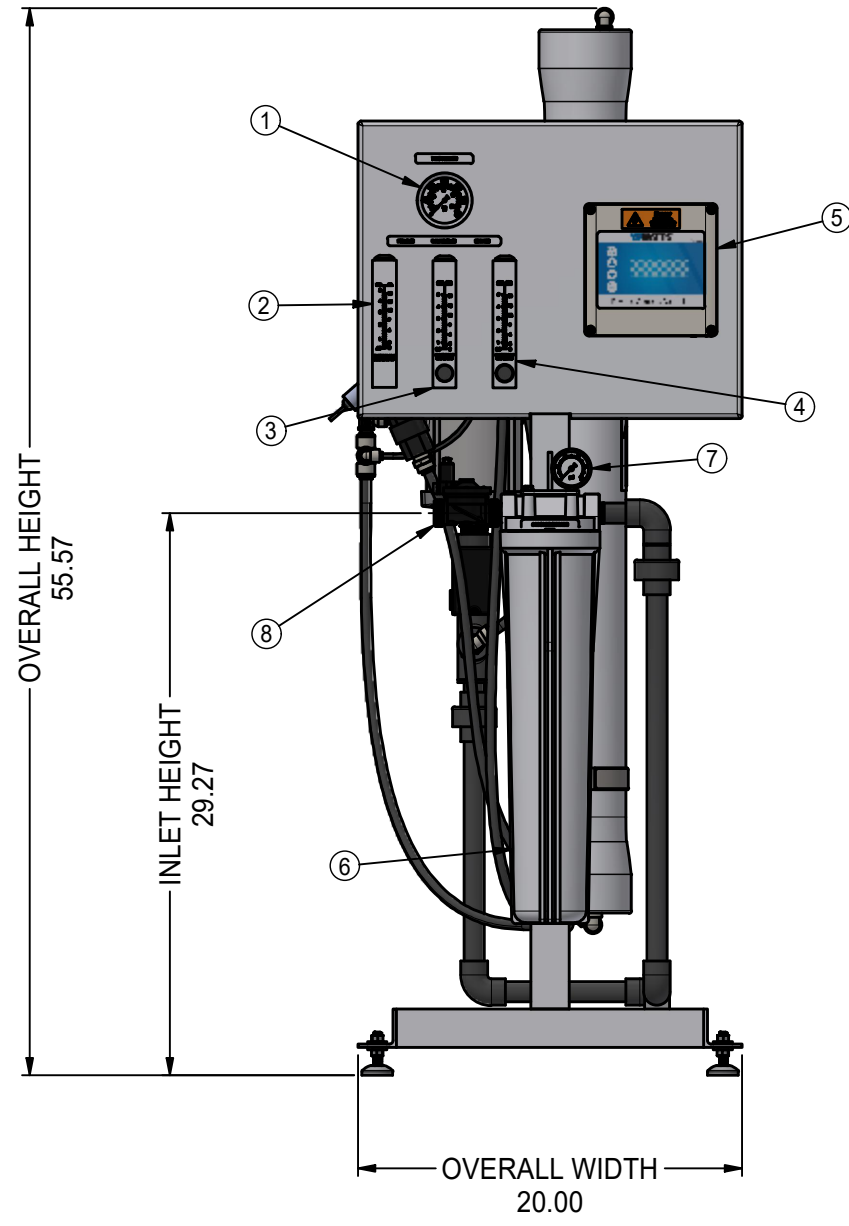

FRONT VIEW

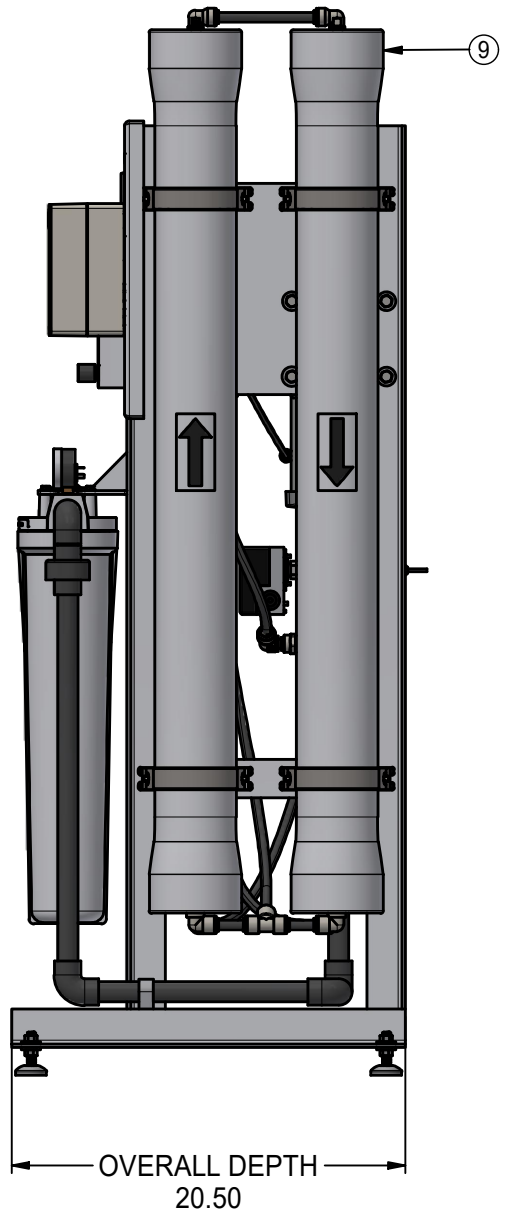

SIDE VIEW

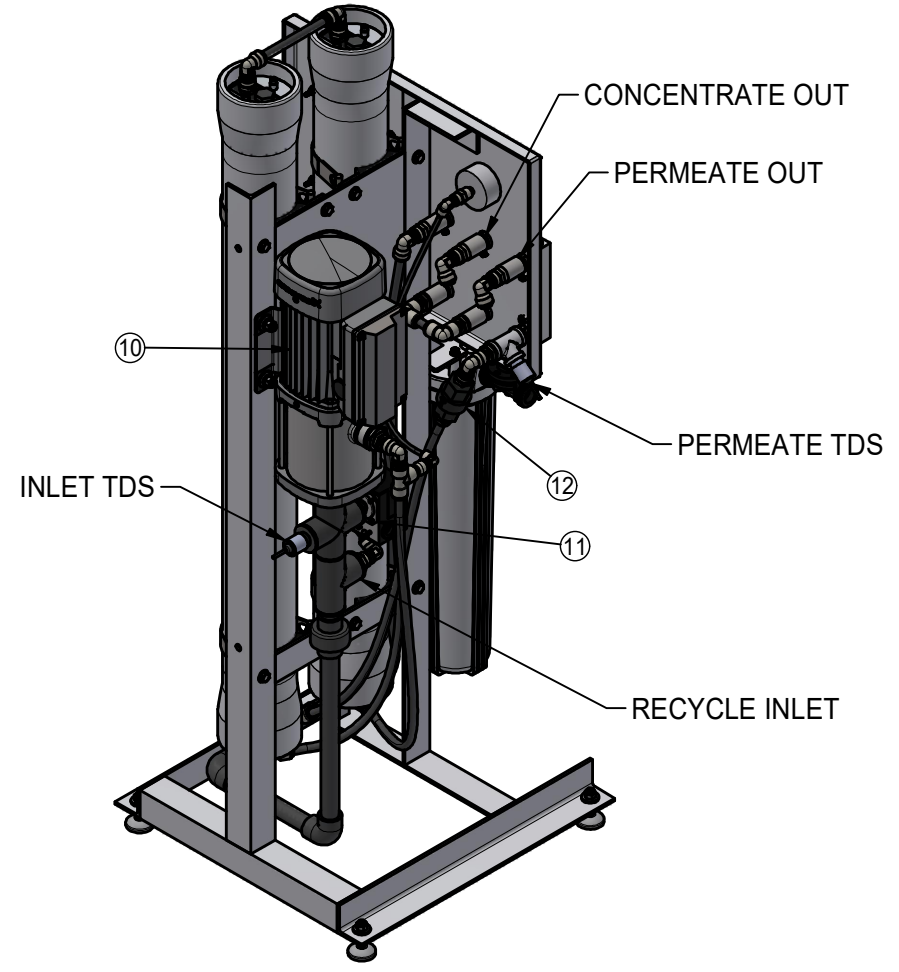

ISOMETRIC VIEW

REV	DESCRIPTION	DATE	REV BY
1	INITIAL RELEASE	7/1/2025	OR

REVISION HISTORY

UNLESS OTHERWISE SPECIFIED		APPROVALS (CURRENT REVISION)		EDP NO.	68111205
1. DIMENSIONS ARE IN INCHES		PREPARED	DATE	LEGACY NO.	
2. INTERPRET DIM. & TOL. PER ASME Y14.5M - 1994		renesoo	5/9/2025		
3. ALL SHEETS ARE SAME REVISION		CHECK	DATE	FORMAT	
4. DO NOT SCALE DRAWING				INVENTOR	
5. BREAK ALL SHARP EDGES AS REQ'D		MATERIAL			
TOLERANCES ARE:		OTHER			
DECIMAL	.X ± 0.1	MACH	±0° 30'	ANGLES	FORMED ±2°
.XX ± 0.03					
.XXX ± 0.010					
COMMON AXIS	0.015 TIR	SURFACE FINISH	125 µIN RMS		



THIS DRAWING DISCLOSES CONFIDENTIAL AND PROPRIETARY DATA OWNED BY WATTS WATER TECHNOLOGIES, INC. AND MAY NOT BE USED OR DISCLOSED TO OTHERS WITHOUT THE PRIOR WRITTEN CONSENT OF WATTS WATER TECHNOLOGIES, INC.

TITLE		RX-4040-02-1	
SIZE	B	DWG NO.	68111205
SCALE:	NTS	REV	1
		SHEET 1 OF 2	

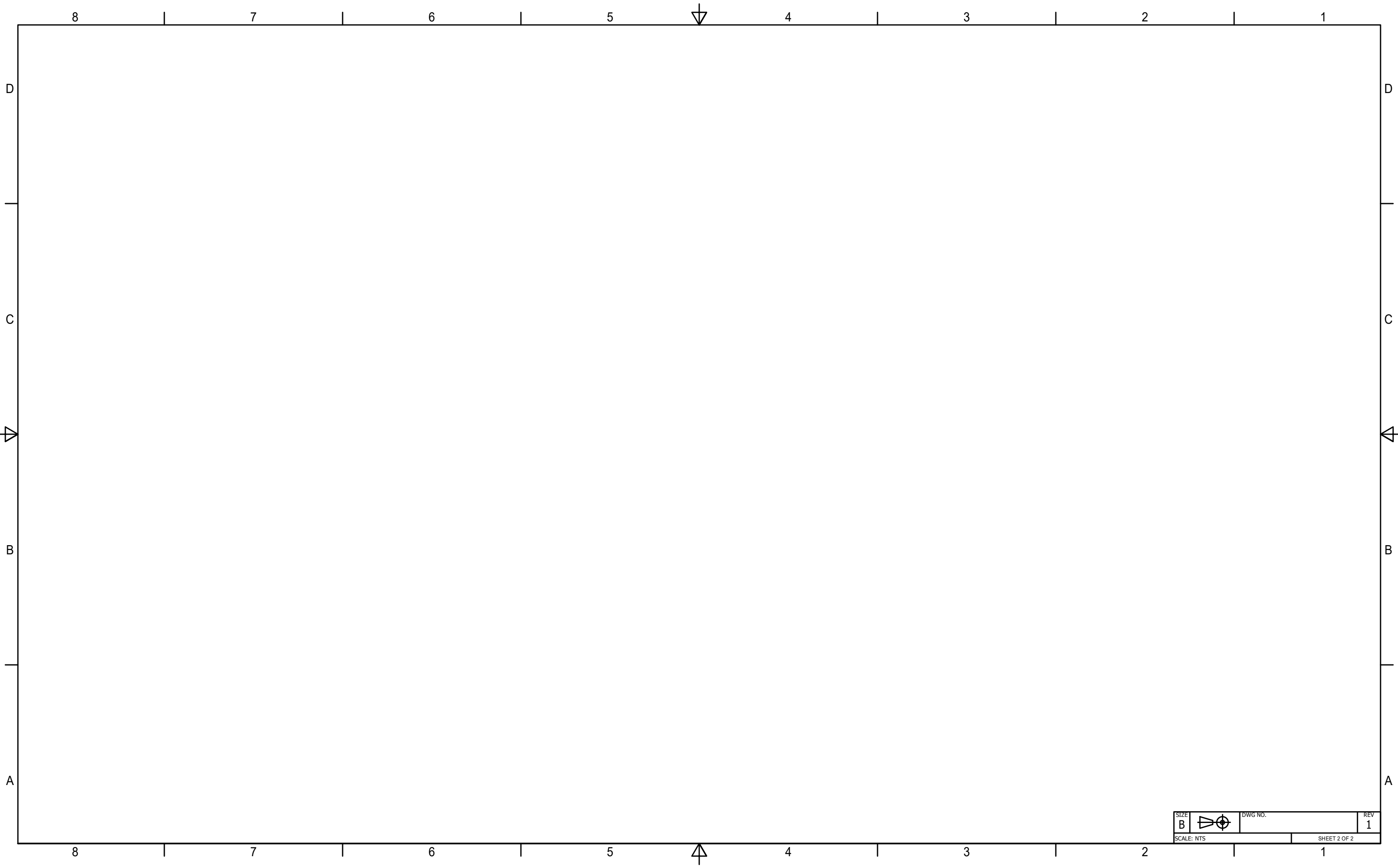

SIZE B	DWG NO.	REV 1
SCALE: NTS		SHEET 2 OF 2