

Engineering Specification

Job Name _____
 Job Location _____
 Engineer _____
 Approval _____
 Tag _____

Contractor _____
 Approval _____
 Contractor's P.O. No. _____
 Representative _____

CO-100-C-TS Floor Cleanout with Square Top, Tile Recess

Specification

Watts CO-100-C-TS epoxy coated cast iron cleanout with anchor flange, reversible membrane clamp, and adjustable combined access cover and plug with gasket seal.

Pipe Sizing		
Suffix	Description	
2	2"(51) Pipe Size	<input type="checkbox"/>
3	3"(76) Pipe Size	<input type="checkbox"/>
4	4"(102) Pipe Size	<input type="checkbox"/>
6	6"(152) Pipe Size	<input type="checkbox"/>

Outlet Type		
Suffix	Description	
NH	No Hub (MJ)	<input type="checkbox"/>
P	Push On	<input type="checkbox"/>
T	Threaded Outlet	<input type="checkbox"/>
X	Inside Caulk	<input type="checkbox"/>

Options		
Suffix	Description	
-6	Vandal Proof	<input type="checkbox"/>
-13	Galvanized Body	<input type="checkbox"/>
-34G	Gas Tight ABS Expansion Plug (n/a to 6" Connection)	<input type="checkbox"/>
-113M	Special Epoxy from 3M Range	<input type="checkbox"/>
-SO	Side Outlet	<input type="checkbox"/>

Optional Body Material (NH Only)		
Suffix	Description	
-60	PVC Body w/Socket Outlet	<input type="checkbox"/>
-61	ABS Body w/Socket Outlet	<input type="checkbox"/>

Suffix	Load Rating
TS-1	MD

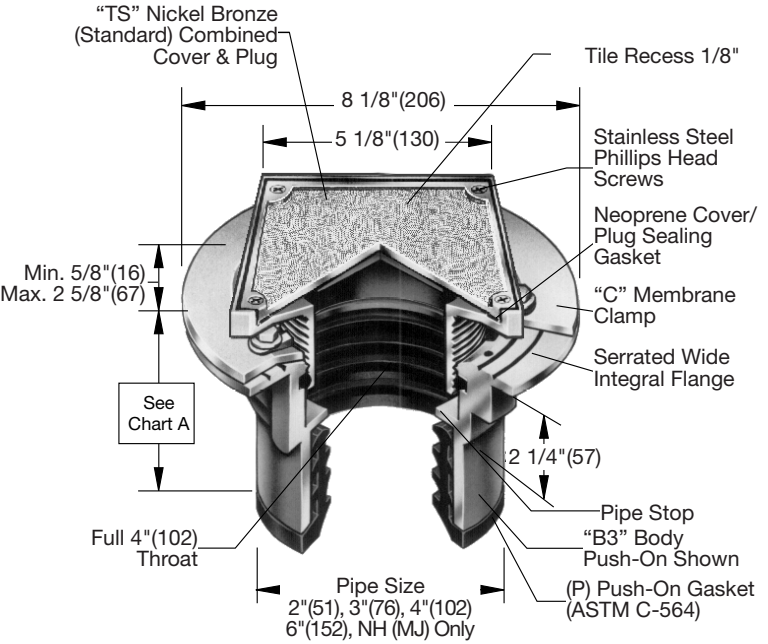

NOTICE

The load classifications are in accordance with the American National Standards A112.21.1M ASME Ratings are as follows:
 MD - Safe Live Load 2000-4999 lbs. (900-2250 kg)
 These categories are given as a guide only. Please consult factory.

NOTICE

The information contained herein is not intended to replace the full product installation and safety information available or the experience of a trained product installer. You are required to thoroughly read all installation instructions and product safety information before beginning the installation of this product.

Chart A

Pipe Size	Std.	P	T	X	60/61
	No Hub	Push On	Female Thread	Inside Caulk	PVC/ABS
2"(51)	3-5/8"(92)	4-1/4"(108)	4-1/4"(108)	4-1/2"(114)	3-3/4"(95)
3"(76)	3-5/8"(92)	4-1/4"(108)	4-1/4"(108)	4-1/2"(114)	3-3/4"(95)
4"(102)	3-5/8"(92)	4-1/4"(108)	4-1/4"(108)	4-1/2"(114)	4"(102)
6"(152)	3-1/2"(89)				

Watts product specifications in U.S. customary units and metric are approximate and are provided for reference only. For precise measurements, please contact Watts Technical Service. Watts reserves the right to change or modify product design, construction, specifications, or materials without prior notice and without incurring any obligation to make such changes and modifications on Watts products previously or subsequently sold.



USA: T: (800) 338-2581 • F: (828) 248-3929 • Watts.com
 Canada: T: (888) 208-8927 • F: (888) 479-2887 • Watts.ca
 Latin America: T: (52) 55-4122-0138 • Watts.com